

FISSLER
ELEKTRONIK

FMSC

Safety
controller

Modular and
configurable



HOMEPAGE

FMSC



Our vision:

We protect people from accidents and have convincing high quality innovative, user-friendly safety solutions for the customers and are always willing to provide the customer with help and advice.

Our passion:

Fiessler Elektronik has been producing optoelectronic components for the industry since 1956. The resulting development and production of the first fully electronic safety light curtain and safety light grid on the basis of the transmitter-receiver principle began in 1965.

Nearly 30 years later in 1996, Fiessler Elektronik was the first manufacturer worldwide to introduce the groundbreaking innovation of a specially coupled motion safety solution for blanking presses (AKAS®).

In 2005, Fiessler Elektronik completed its solution for blanking presses with its programmable FPSC safety control.

Permanent product care and new developments in dialogue with our customers is what guarantees perfect solutions and high quality products. Certifications, quality monitoring and prototype tests in accordance with worldwide standards are a matter of course for Fiessler Elektronik.



Company
description



Service – worldwide

Fiessler Elektronik serves customers in all industrial regions of the world. The service network of Fiessler Elektronik is available in more than 30 countries.

These support points provide effective supervision to machine manufacturers as well as end users.



Branches



Quick and flexible

Fiessler Elektronik has consequently implemented its more than 60 years of experience and know-how with the new and configurable modular FMSC safety controller. The development not only focused on the high standard of safety but also on how to simply and rapidly implement projects. Miscellaneous functionalities, such as creating combinations, make it easier for the user to program the safety controller. Already created projects can also be comprehensively documented. Rapid response times as well as the safety-oriented monitoring of up to 17 axes round off the profile of the new FMSC safety control.

The modular structure of the FMSC system family ensures that the most efficient hardware solutions will always be found for a monitoring task. The variations Eco, Basic, Advanced and Professional provide a selection of different master devices with a respectively different range of functions. The corresponding functionalities are simply integrated or configured with the programming software, FMSC Studio. The system can be expanded at any time with up to 16 expansion modules. As a result, up to 204 digital inputs and up to 153 digital outputs are available today. And up to 17 axes can be monitored for safety. The compact design makes it easy to integrate the safety control in new systems as well as for retrofitted systems.

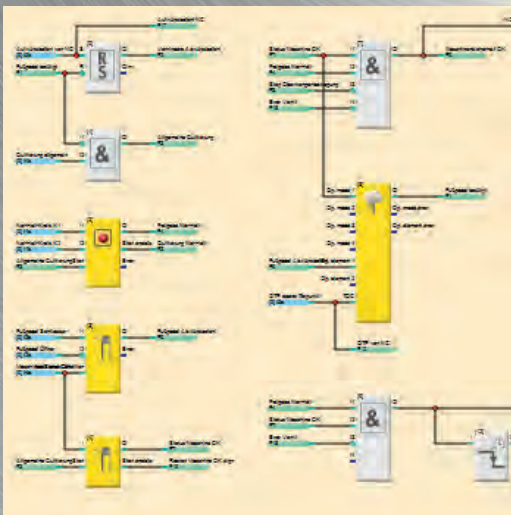

The programming

The programming environment, FMSC Studio, is the heart of the FMSC safety controller. This software tool will configure all hardware functionalities and create the user program. A great number of pre-finished standard and safety function blocks simplifies the work for the user. Using drag and drop, the modules are placed on the worksheet, which accepts nearly any size, and the individual I/O points are simply graphically connected. Transfer flags do not have to be set necessarily, since FMSC Studio supports both work methods. The individual windows are arranged in a clear and flexible manner to provide an optimal overview at all times.

The simulator

The created project can be simulated and tested practically in real time with the built-in simulator. Counters, switching on and off times can be integrated and simulated. As such, the dynamic behavior of connected actuators or higher level controls can be simulated on a nearly 1:1 basis. It is also possible to integrate special modules to simulate short circuits and interruptions in performance. The user is thus able to commission the project as well as carry out a safety-related inspection from their workstation. Different simulators can be used to accurately document the individual test stages of a project. Preliminarily inspecting the created project at the workstation saves a lot of time and money when commissioning the real machine or system.

The online diagnostic

The software tool FMSC Studio also forms the basis for the online diagnostic of the FMSC safety controller. Individual networks as well as the complete project can be diagnosed online. Non-volatile error memories make it easier to find sporadic errors in the wiring and the function. Showing the project history of the device also makes its life cycle accountable at all times.

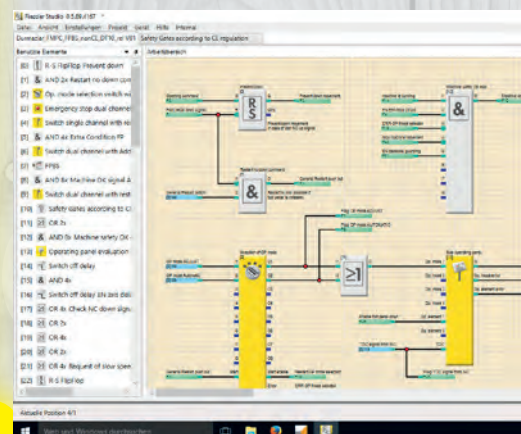
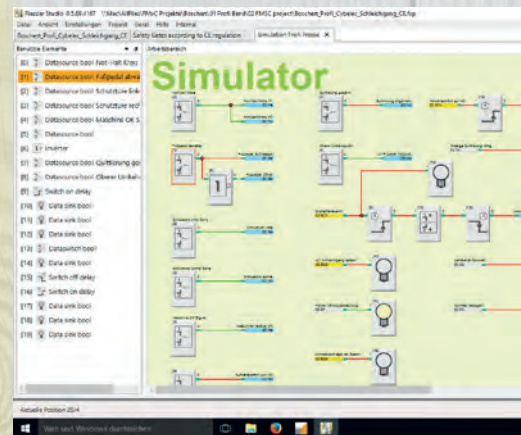
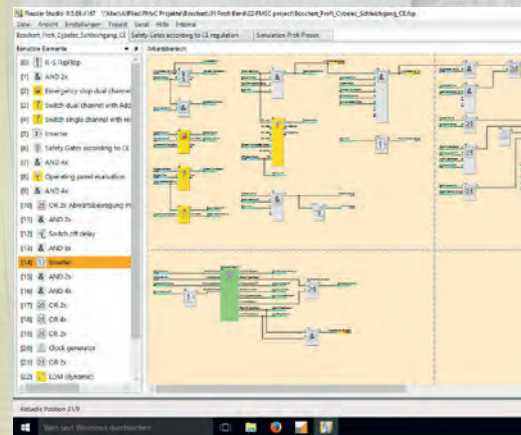



Emergency shutdown

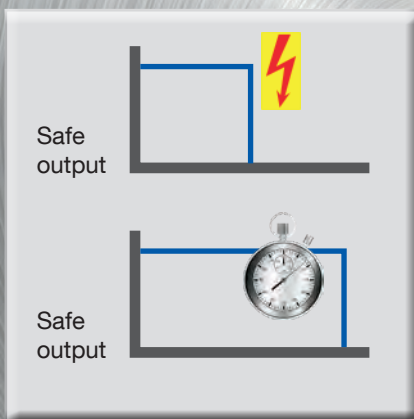

Switch-off delay

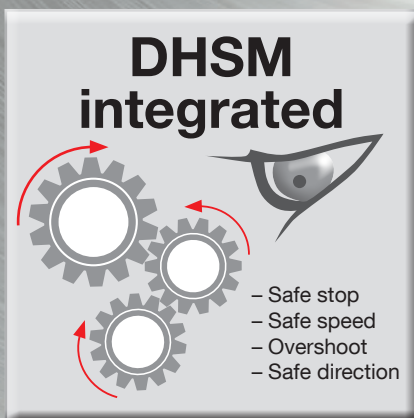

Dynamic High Speed Monitoring

The FMSC system family has the right solution for each task. Comprehensive functions enable maximum flexibility with a convincing cost-benefit ratio.

Examples:

Emergency shutdown (fast shutdown function)

If the rather fast cycle time of the FMSC is still too slow, the hardware configurator can configure the emergency shutdown. The maximum switch-off time then is 0.5 ms. To ensure every single application has an optimal shutdown behavior, the emergency shutdown can be bypassed in the application program according to situation. This provides maximum flexibility regarding an emergency shutdown.

Switch-off delay of outputs - also in case of a fault

For many applications, the switching off behavior of safety controllers in case of a fault leads to risks for humans and machine. Conventional safety controls for internal or external hardware errors set all outputs to the secure state, resulting in the development of dangerous centrifugal forces. To exclude these hazards outright, the FMSC system family has a configurable switch-off delay for every single safety output. This specific type of shutting down offers protection from consequential damage.

Speed monitor – safe, flexible and fast

The FMSC system family can safely monitor up to 17 axes. Different, pre-finished software modules cover any application as per EN 61800-5-2. For example, different speed profiles to be monitored can be allocated to an axis. Direction and standstill detection round off the requirement profile. The counter pulses are evaluated in DHSM mode (dynamic high speed monitoring). This allows an adequate response to the fastest events. Direction of rotation, resolution and sensor types can be simply and readily selected from the hardware configuration. The individual counter values are then processed further in the FMSC application program.

- Safe Stop 1: SS1
- Safe Stop 2: SS2
- Safe direction of movement (safe direction): SDI
- Safe operation stop: SOS
- Safe speed monitor: SSM
- Safe speed range: SSR
- Safe maximum speed / safely limited speed: (SLS)

Range of functions Motion

SS1 – safe stop 1

The SS1 function corresponds to stop category 1 according to EN 60204-1.

The drive is driven to a controlled standstill and the braking ramp can be monitored. The safety function STO is then activated.

The safe stop can be either

– **not monitored** (STO is activated time-controlled, independent of reached standstill)

or

– **monitored** (STO is only initiated after standstill)

executed.

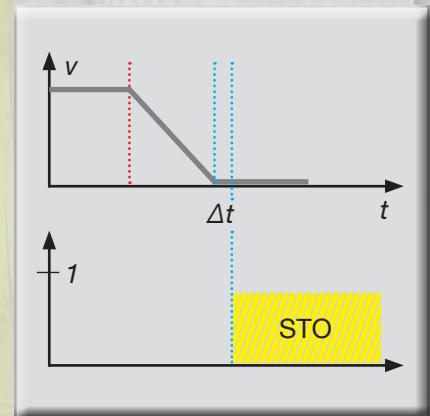

– Function freely programmable and adaptable to the application with

- various tolerance windows
- Additional monitoring of braking ramp

SS2 – safe stop 2

The SS2 function corresponds to stop category 2 according to EN 60204-1. Therefore, SS2 must not be used for emergency stop functions.

The drive is driven to a controlled standstill and remains closed-loop controlled at standstill. The standstill is monitored in a safe way (SOS function). In practice, due to the control fluctuations of the drive, a harmless small change in position around the setpoint value is permitted. If the monitoring limits are exceeded, a reaction is initiated (e.g. safety function STO). The safety function SS2 has the advantage that the DC link of inverters is not discharged and the drive is immediately ready for operation. This is an advantage, for example, when setting up with an enabling mode.

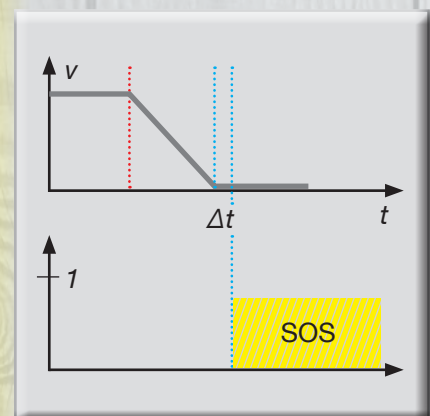

– Function freely programmable and adaptable to the application with

- various tolerance windows
- Additional monitoring of braking ramp

Range of functions Motion

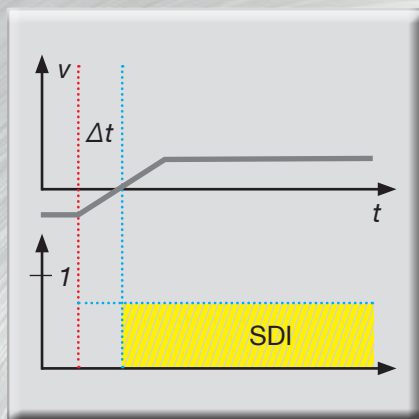

- Safe direction monitoring with
 - direction preselection
 - bypass function
 - Parameterizable tolerance window
- Extensive diagnostic options

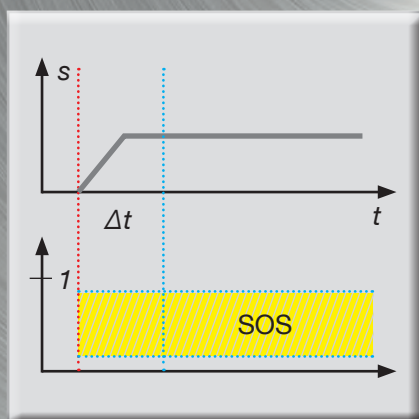

- Safe standstill monitoring with parameterizable speed window
- Extensive diagnostic options

SDI – safe direction identification

The drive is monitored to be sure that it only works in the enabled direction, e.g. that a shaft only rotates clockwise, a linear axis can open a danger point but cannot close as well.

SOS – safe operating stop

The safety controller FMSC monitors that a position is safe. The drive may move in a defined position window. When leaving the window, a suitable error reaction occurs, e.g. STO. Depending on the dimensions of the monitoring window, standstill or remaining in a certain position range can be monitored.

Range of functions Motion

FISSLER
ELEKTRONIK

SSM – safe speed monitoring

The safe control FMSC monitors whether a minimum speed is not undershot. If the speed falls below the speed limit, a suitable error reaction takes place. In this way it is possible to react to blocking of a drive with STO, to low speed of a pump with activation of a reserve unit.

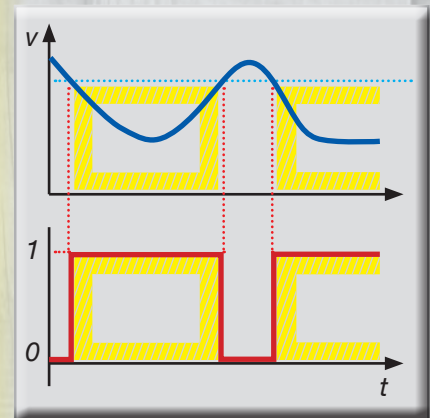

- Safe speed monitoring with
 - lower limit
 - Parameterizable tolerance window
- Filtering of undesired signal peaks
- Bypass function for e.g. commissioning situations
- Extensive diagnostic options

SSR – safe speed range

The drive is monitored for compliance with a certain speed range.

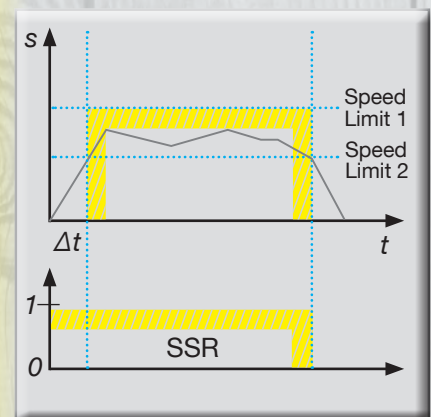

- Safe speed monitoring with
 - upper and lower limit
 - Parameterizable tolerance window
- Up to 3 profiles can be parameterized per function block
- Spoil filter for unwanted signal peaks
- Extensive diagnostic options

Range of functions Motion

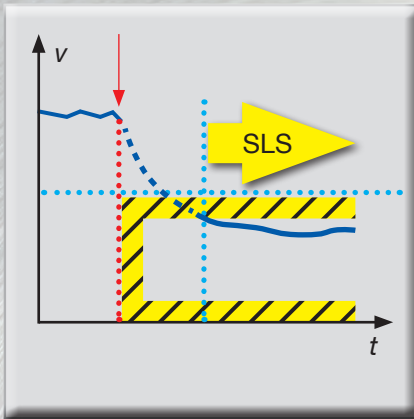

- Safe speed monitoring with
 - upper limit
 - Parameterizable tolerance window
- Filtering of unwanted signal peaks
- Bypass function for e.g. start-up situations
- Extensive diagnostic options

SLS – safely limited speed

The safe control FMSC monitors that a maximum speed is not exceeded. When the speed limit is exceeded, a suitable error reaction such as SS1, STO and engagement of a brake occurs.

Your advantages

FISSLER
ELEKTRONIK

Expanding the system structure

Up to 16 expansion modules can be connected to a single master module. Configuring the respective expansion modules is quite simple. Addresses are taught using the teach-in function, but the addressing does not have to be uniform. The advantage is that diverse machine options can be planned already during project planning and then implemented later on. This in turn considerably simplifies the creation of circuit diagrams and documentations.

Muting safe bypassing of an optical protection system

For many applications, materials need to be transported in to or out from the area to be protected. An optical protection, however, would shut down the system each time because the material interrupts the light curtain. The safe Muting function bypasses the light curtain for the duration of the transport. Depending on the set-up, this is called serial or parallel muting. The override function can bypass the light curtain at any time, helping to recover the system after a standstill and interrupted light curtain. The pre-finished and certified modules of the FMSC system family supports all muting arrangements.

Cycle operation – a light curtain not only for safety

To increase the ergonomics at the machine workplace, an operating step is initialized with the cycle operation via the safety light curtain. Also, productivity at many manual feed workplaces is significantly increased because extra equipment does not need to be activated to trigger the operating step. Depending on machine type, up to four interruptions can be programmed to trigger the operating step. Typical application areas are presses and automatic testing devices that are loaded by hand.

Programmable light curtain BLVT/BLCT

A safety concept with optical protection must be flexible and capable of adapting to the respective requirement. If not, the motivation to manipulate the optical protection increases because the safety concept is deemed as interference while working. With the safety light barrier BLVT/BLCT and the safety controller FMSC, up to eleven operating modes can be configured and called up during operation. This is done either with the teaching-in function or direct retrieval from a defined memory. The safety concept can be flexibly adapted to requirements at any time.

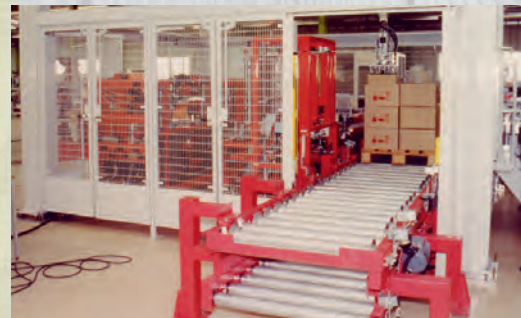

Muting

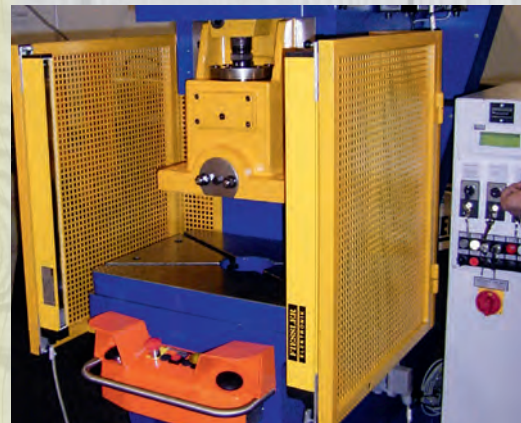

Cycle operation



Light curtain BLVT/BLCT



Numerous FMSC master devices are available with the same hardware structure but with a different range of functions. The user thus can create a system concept with the best cost-benefit factor.

FMSC- ECO – Master

- 12 digital inputs
(six inputs for 24V or 5V DC configurable)
- 4 safe digital outputs
- 5 standard outputs (each configurable as test pulses)
- 1 two-digit display for messages
- 1 USB programming interface
- 1 start-stop push button

FMSC- Basic – Master

(additional range of functions for Eco variation)

- Expandable with up to 4 expansion devices
- Configurable switching-off delay of safe outputs in case of error

FMSC- Advanced – Master

(additional range of functions for Basic variation)

- Expandable with up to 8 expansion devices
- Configurable emergency shutdown of safe outputs (fast shut down function)
- Counter inputs for the safety-related evaluation of an axis
- Muting functions
- Safety light curtain BLVT programmable

FMSC- Professional – Master

(additional range of functions for Advanced variation)

- Expandable with up to 16 expansion devices
- Counter inputs for the safety-related evaluation of up to 17 areas in combination with FMSC-Professional-Slave

Expansion modules

FISSLER
ELEKTRONIK

Depending on the master device, the system structure can be expanded with modules to a maximum of 16 devices. The devices are respectively addressed via a simple teach-in process.

FMSC- Basic – Slave 1

- 12 digital inputs
(six inputs for 24V or 5V DC configurable)
- 4 safe digital outputs
- 5 standard outputs (each configurable as test pulses)
- 1 two-digit display for messages
- 1 start-stop push button
- Configurable switch-off delay of safe outputs in case of error

FMSC- Advanced – Slave 1

(additional range of functions for Basic variation)

- Configurable emergency shutdown of safety outputs (fast shut down function)

FMSC- Professional – Slave 1

(additional range of functions for Advanced variation)

- Counter inputs for the safety-related evaluation of an axis (up to 17 axes in overall expansion)



4 Amps
per safe
output

Communication modules



FMxC Slave Modbus ASCII

Fieldbus expansion with Modbus ASCII Communication.

- RS232 / RS485 interface
- 29 x 32 Bit Message inputs
- 29 x 32 Bit Message outputs
- Blanking modes programming on BLxT light curtains



FMxC Slave EtherCat

Fieldbus extension with communication EtherCat

- 2 x RJ45 EtherCAT interface
- 28 x 32Bit Message inputs
- 29 x 32Bit Message outputs
- Blanking modes programming on BLxT light curtains

Safe contact extension

FISSLER
ELEKTRONIK

FMSC-R / FMSC-2R

Application

The contact extension FMSC-R/2R is used for extension, contact amplification and galvanic isolation of the safety outputs of the FMSC safety controller. This enables the switching of different potentials and circuits, even with high loads.

Depending on the type the device offers:

- FMSC-R a relay function according to PL e according to ISO 13849-1
- FMSC-2R two relais functions according to PL e according to ISO 13849-1

Scope of functions

- Integration of the FMSC safety controller into other potentials without loss of safety
- 1/2 safety circuits each with 3 undelayed positively driven safety contacts
- Feedback circuit for relay monitoring at the control unit
- Diagnostic LEDs for the switching status of the safety contacts



Due to the open system structure, the FMSC system family is suitable for all industrial fields of application. Examples:

Sheet metal work in general

Evaluation of emergency stop, optical protective devices, safety doors, positions and speeds.

- Shears
- Press brakes
- Mechanical presses
- Punching, laser, water cutting systems



Conveying technology

Evaluation of emergency stop, optical protective devices, safety doors, speeds, muting applications, enabling mode

- Packaging machines
- Conveyor systems in general
- Sorting systems



Machining centers

Evaluation of emergency stop, optical protective devices, safety doors, safe speed, enabling mode.

- Milling centers
- Lathes
- Drilling machines



Special machines / Automatic testing devices

Evaluation of emergency stop, optical protective devices, muting, cycle mode, safety doors, feeding units.

- Automatic testing device with manual loading
- Automatic punching press
- ...



Robot applications

Evaluation of emergency stop, optical protective devices, safety doors, safe work areas, safe speeds, area safeguarding

- Automatic feeding units for presses, punching machines, etc.
- Fully automatic machining centers
- Packaging machines

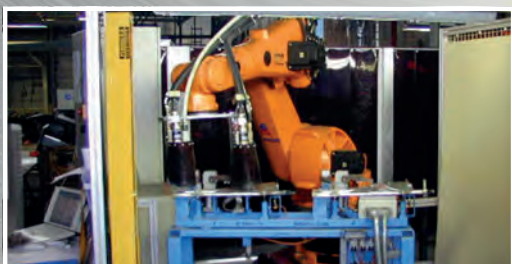

All features at a glance

FISSLER
ELEKTRONIK

Shutting down quickly

The FMSC has convincingly rapid cycle and response times. And yet, sometimes shutting down needs to occur as quickly as possible. For that reason, the hardware configurator can parameterize the emergency shutdown with a maximum shutdown time of 0.5 ms. For each application to exhibit the optimal shutdown behavior, the emergency shutdown in the application program can be bypassed according to situation. This guarantees maximum flexibility regarding an emergency shutdown.

Shutting down without risk

Conventional safety controls automatically set all outputs immediately to the safe state in case of internal or external hardware errors. All connected devices and machines, such as robots, immediately stand still. However, the resulting centrifugal forces can put humans and machines at considerable risk. To prevent such risks from even occurring, the FMSC system family has a configurable switching-off delay for every single safety output. The specific shutdown excludes subsequent hazardous potentials.

Simply program –

Find errors online - expand individually

The programming software FMSC Studio lets you easily configure hardware and applications thanks to the pre-finished standard and safety function blocks. The user drags the modules and drops them on the worksheet and simply connects the I/O points graphically. An additional bonus: FMSC Studio diagnoses the complete project or individual networks online. The system can be expanded with up to 16 hardware modules for new tasks. Configuration occurs via teach-in function, but the addressing does not have to be uniform. Diverse machine options can be planned already during project planning and then implemented later on.

Safe in every respect

The ingenious safety concept of the FMSC system family begins already during the programming: The "hardware force connect" function displays possible errors to the project planner while creating the application software. By entering different passwords, the control can be protected from unauthorized access. This function also guarantees a comprehensive know-how protection. By using pre-finished certified software components including a program simulator, the highest possible safety-related standards can be achieved in accordance with relevant safety standards.

FMSC properties

- Emergency shutdown (fast shutdown function) max 0.5 ms
- Switching-off delay of safe outputs, also in case of error
- Up to 17 axes can be safely monitored
- Expandable with up to 16 expansion modules
- Very fast cycle times
- Easiest programming
- Versatile certified software modules
- Cost-effective system structure through use of expansion modules
- Short standstill times through extensive diagnostic possibilities
- Comprehensive know-how protection by setting different access passwords
- Maximum safety
 - PL e
 - SIL CL 3
 - CAT 4
- Realization of safety functions in acc. with EN 61800-5-2
- Connection to different field bus systems

The FMSC Studio software can be used to not only program the FMSC system family but also to easily put into operation. A project is simply created using drag and drop and can be directly simulated at the workstation.

Your advantages at a glance:

- Intuitive and simple operation simplifies the entry into the FMSC system
- Detailed and detailed online help for each functionality and for all function blocks
- Large number of certified software components simplifies project implementation
- Docking and undocking windows support individual working methods and multi-screen workstations
- Offline commissioning with the help of simulators, which can be created several times
- Creation of your own software modules, which can be easily exported or imported. Thus own function block libraries can be created, which bring substantial time advantages for the project engineering.



FMSC Studio – Workstation environment

With this software a project is created according to the respective specification. The applications are implemented quickly and easily with the help of numerous certified software modules. Another technical feature is the creation of subroutines, so-called combinations. These can be easily exported and quickly imported into other projects. In this way, program passages that have already been tested can be quickly and easily integrated into other projects. Thus, the creation of new projects is much faster - and therefore cheaper -.

Die FMSC Studio-Software enthält die Module

- Project creation
- simulator
- online diagnosis

FMSC Studio – Simulator

The simulator is used to verify and test a complete project offline at the workstation. The simulator can simulate nearly every time behavior. If several simulators are used, the project planner can check all error cases and file them with the project for documentation purposes.

The use of the simulator considerably reduces the commissioning time at the real machine, because the logic has already been tested in advance.

FMSC Studio – Online Diagnostics

The FMSC Studio software in online mode supports commissioning directly at the machine. All networks and combinations can be diagnosed online. This guarantees fast commissioning. Program history as well as error stack display support the technician to give him an overview at all times.

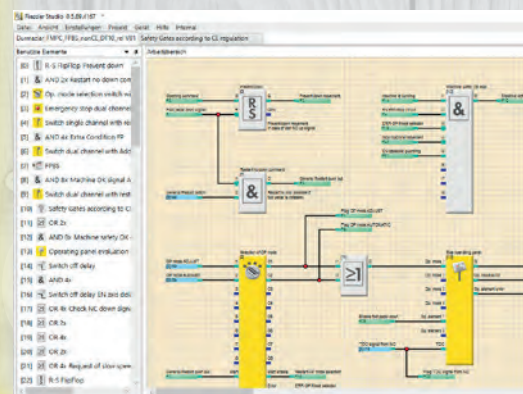
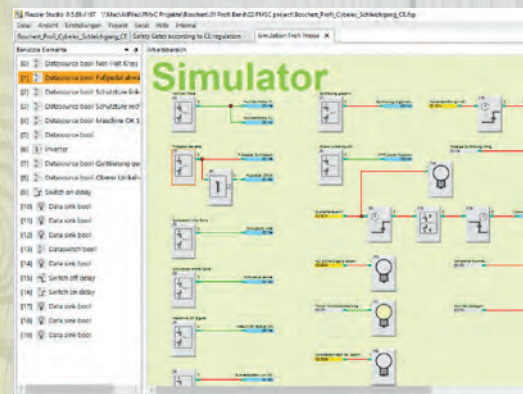
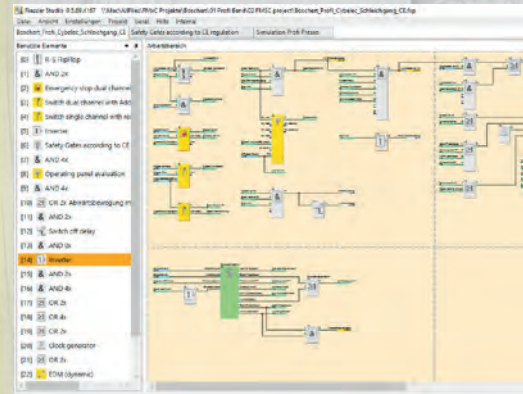

FMSC Studio Professional

With this version of the FMSC Studio software you get an even more powerful tool, which mainly supports you in the diagnosis of a plant/machine.

The FMSC Studio Professional software contains the following

- Project creation
- simulator
- online diagnosis
- Recording of signals in real time

FMSC Studio Professional – Recording function

This function can be used to record signals in online mode as well as in the simulator. This means that service technicians can be supported much better on-site.

The recording function offers the following features:

- Recording of signal states in the project in online mode as well as in the simulator
- Records can be analyzed at the desk
- Passing on the recording files e.g. by email
- Playback of the project with time stamp
- Decrease playback speed to capture complex correlations
- Setting of read or jump marks for marking important events

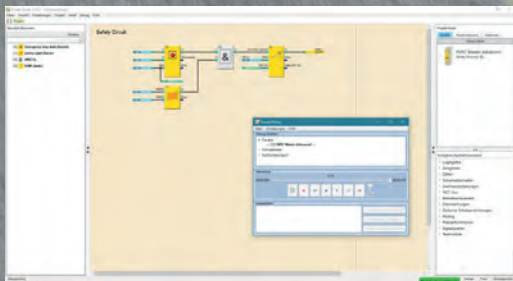

FMSC Studio Transfer Tool

The software FMSC Studio Transfer Tool is the simple tool for service technicians. The tool offers the following functionalities:

- Up and download of FMSC projects
- Displaying the hardware error codes stored on the device
- Opening the Studio Help

FMSC projects cannot be modified or analyzed with this software version. This means that no errors can be made when the control components are replaced.

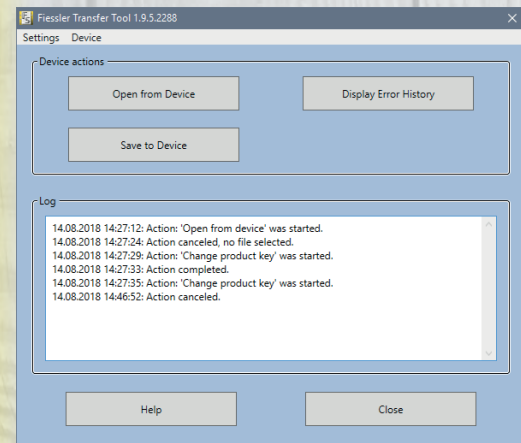
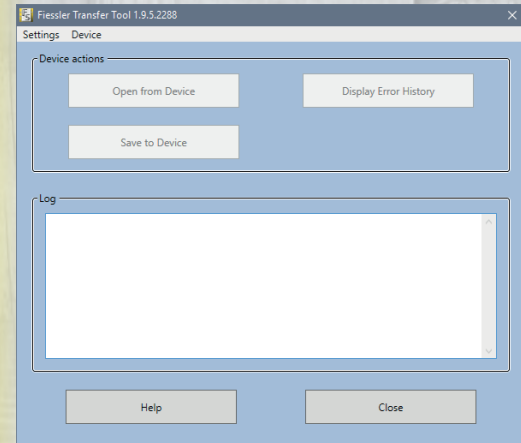

Individual solutions

User optimized prefabricated controls

Do you need a safety-related control in large quantities and would like support in implementing the application program? Then just ask us.

Fiessler Elektronik will help you implement the entire project and supply the prefabricated control directly to your company. This keeps the expenditure for the safety concept at a manageable level and you can focus on your core competency.

Do you need specific safety-related functionalities for your application? In this case **Fiessler Elektronik** will also be able to help you. We will accompany and support you beginning with the development of the specification to the implementation of software modules and on to the certification.

The system structure of the FMSC Studio programming software has been designed so that the components can be used exclusively specific to customer. This means that all of your incorporated know-how will also be only available to you.



Our experience for your safety



You will be competently advised on site and by telephone by our field representatives and technical consultants:

We support machine manufacturers and end customers in assessing possible dangers and determining necessary safety categories in order to secure systems according to applicable laws and standards.



Our employees are available for questions and suggestions concerning our products and their integration.



We will check if the circuit diagrams you produced are integrated correctly in the associated safety category.

- Safety inspections before initial start-up
- Annual safety inspections
- Overtravel measurements
- Other safety inspections



Retrofitting of safety devices with subsequent inspection

- Safety seminars, also at the customer's premises
- User training
- Customer-specific training



- Safety light barriers
- Safety controls
- AKAS® integrator training
- FMSC integrator training
- Application engineering of safety light curtains, light grids, light barriers

Application advice

Support for Risk analysis

Technical Support

Circuit diagram processing

Standard safety checks

System modernization

Safety training courses

Product training

Innovative solutions

Safety light curtains

Type 4, SIL 3, PL e
Type 2, SIL 1, PL c
high range up to 60 m
Safety controller integrated

Blanking and cascading
Protective field height up to 2500 m
Very short response time as of 2 ms
Finger and hand guard, entrance protection

AKAS® press brake safety system

fully automatic adjustment
after tool change
laser-optics safety light grid

innovative finger guard through
continuous bending without stop

FMSC safety PLC

Emergency shutdown
(fast shut down) max. 0.5 ms
Expandable with up to 16 expansion modules

Easiest programming
Cat 4, SIL 3, PL e

Safety contact mats

Type 3, SIL 2, PL d
Series connection of up to
ten mats
Load capacity up to 2000N
single component casting also
in several colors

individual sizes and shapes
Polyurethane, aluminum or
Stainless steel surface
with integrally cast ramp rail
available

Safety laser scanner

Cat 3, SIL 2, PL d
Protective field 4 m, range 7 m
Metering section 50 m range

Easy assembly
Warning field 15 m
Several programmable sections

Safety foot pedals

Single-pedal or double-pedal

Controlling, detecting and measuring

Measuring light curtains
Loop sensors
Directional counting light barriers

Hole detectors
Encoding strips

